

General Electric Company

Schenectady, N.Y.

SUPPLY DEPARTMENT

March, 1914

† Bulletin No. 54602

PARTS OF TYPE C-28, FORMS C, D AND E CONTROLLERS

C-28-C CONTROLLER

Cat. No.	Description
34343	Operating handle.....
29184	*Reversing handle.....
	<i>Following are the parts:</i>
151705	Handle body for No. 34343.....
14410	Set screw for No. 151705 ($\frac{5}{16}$ in.—18, $\frac{5}{8}$ in. headless, sherardized, sp'l).....
150143	Grip for No. 34343.....
151706	Latch knob with plunger, for No. 34343.....
150145	Sleeve with pin, for upper end of latch plunger.....
150146	Collar with pin, for lower end of latch plunger.....
150147	Supporting stud for grip.....
151707	Pin for handle body and supporting stud for grip (0 0935 in. by $1\frac{3}{16}$ in.).....
150148	Compression spring for latch knob.....
151708	Long latch lever for No. 34343.....
150150	* Short latch lever for No. 34343.....
151709	Pivot screw for Nos. 151708, 150150 (14—24, $\frac{15}{16}$ in. headless, sp'l).....
151710	Catch for long latch lever.....
150153	Pivot screw for No. 151710 (10—32, $1\frac{5}{16}$ in. headless, sp'l).....
150154	Spring with rivets, for catch.....
40432	CONTROLLER FRAME, complete, fitted with bearing and cap screws for controlling cylinder shaft. Includes pole piece stop, magnet core, binding nut for magnet spool, soft rubber packing and all spring and pivot pins riveted in position.....
150715	Bearing for controlling cylinder shaft.....
133716	Cap screw fastening No. 150715 to frame ($\frac{3}{8}$ in.—16, 2 in. hex. h. slot. sherardized).....
22761	Soft rubber packing for frame.....
22762	Washer strip for packing.....
151711	Screw fastening Nos. 22761, 22762 to frame (10—24, $\frac{3}{8}$ in. f. h. sherardized).....
22763	Binding nut with set screw, for magnet spool ($1\frac{1}{8}$ in.—18, $\frac{1}{2}$ in. thick, $2\frac{1}{2}$ in. across flats, hex. brass, sp'l).....
22764	Set screw for binding nut ($\frac{1}{4}$ in.—20, $\frac{3}{4}$ in. headless, sp'l).....
14646	Hinge bolt with pin and nut, for fastening cover to frame.....
40433	Cap for top of controller.....
22767	Screw fastening cap to frame ($\frac{3}{8}$ in.—16, $\frac{1}{8}$ in. r. h. brass).....
22980	Washer for No. 22767 ($\frac{25}{32}$ in. by $\frac{11}{16}$ in. by $\frac{1}{8}$ in. thick, fiber).....
40434	Water cap for reversing cylinder shaft, with set screw.....
22769	Set screw for water cap ($\frac{1}{4}$ in.—20, $\frac{5}{16}$ in. headless, sherardized, sp'l).....
40435	Sheet iron cover, complete.....
14645	Slotted lug for cover, with rivets.....
22770	HINGED POLE PIECE, complete, with hinge brackets and hinge pins.....
22771	Spring catch, complete, for pole piece, with two screws.....
22772	Screw fastening spring catch to pole piece stop (10—24, $\frac{7}{8}$ in. f. h.).....

NOTE.—The data in this publication are for the convenience of customers, and every effort is made to avoid error, but this Company does not guarantee their correctness, nor does it hold itself responsible for any errors or omissions in this publication. Subject to change without notice.

* Not included in complete controller. Must be ordered separately.

† Supersedes in part Bulletin No. 4613.

GENERAL ELECTRIC COMPANY

54602-2 Parts of Type C-28, Forms C, D and E Controllers

Cat. No.	Description
22773	ARC DEFLECTOR, complete.....
22775	Back plate for arc deflector.....
22776	Division plate for arc deflector.....
1188	Screw fastening back plate to division plates (No. 10, 1 in. f. h.).....

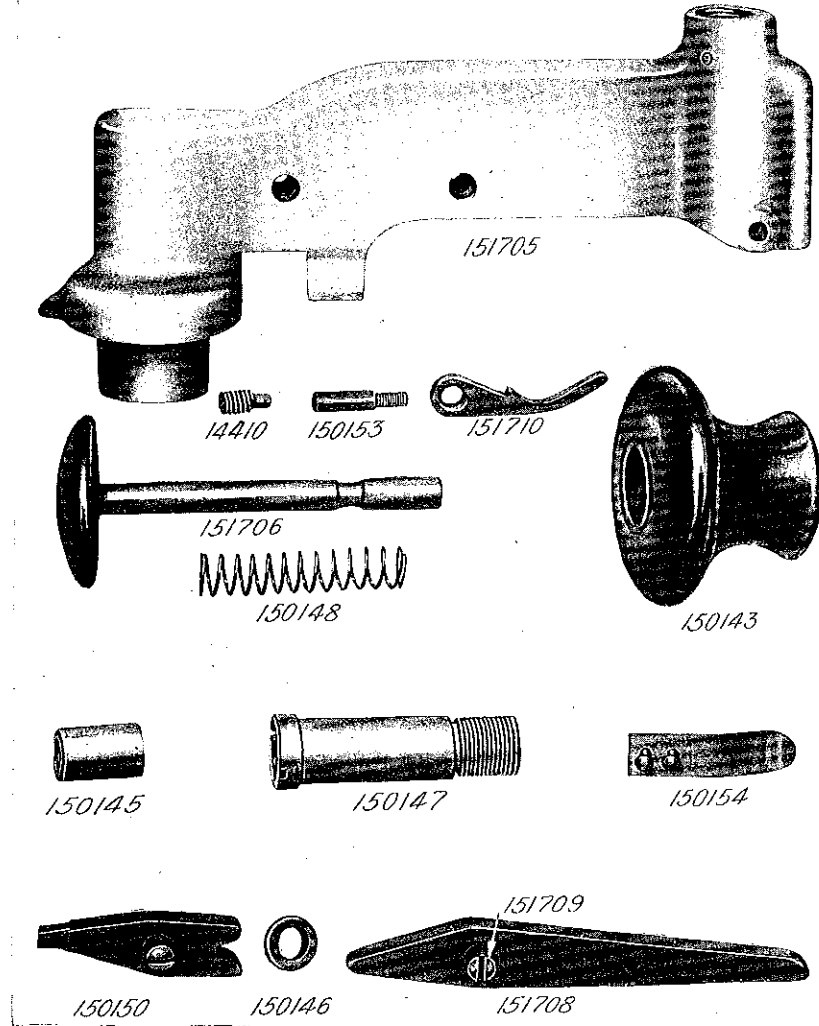

OPERATING HANDLE, CAT. NO. 34343

19628	Screw fastening arc deflector to pole piece (No. 10, 1½ in. r. h. blued).....
13635	Insulating bushing used with No. 19628.....
22777	MAIN MAGNET SPOOL, wound complete, with terminals.....
22778	Copper terminal for magnet spool.....
151712	Screw fastening terminal to magnet spool (14-24, ⅝ in. r. h. sherardized).....
154193	Spring lock washer for No. 151712 (⅜ in. by ⅜ in. by ⅜ in. thick).....
40436	CONTROLLING CYLINDER, complete, with shaft, insulation disks, collar and star wheel....
22782	Insulation disk, upper.....
22783	Insulation disk, lower.....
22784	Collar for shaft, with pin.....
40437	STAR WHEEL with pin, must be fitted.....

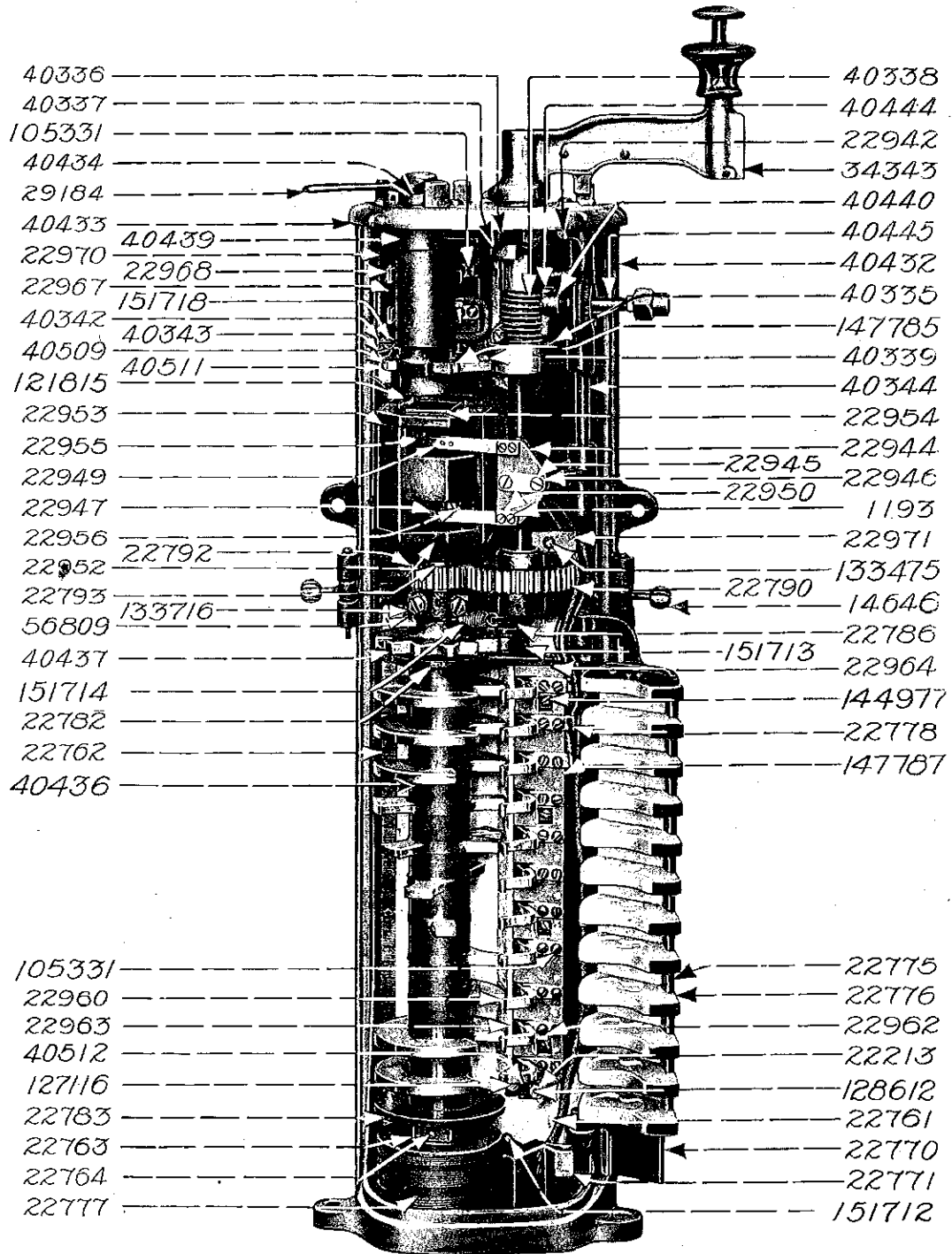

GE PUBLISHED BY BUREAU

C-28-C CONTROLLER

GENERAL ELECTRIC COMPANY

54602-4 Parts of Type C-28, Forms C, D and E Controllers

Cat. No.	Description
22786	Check pawl with roller, for controlling cylinder.
151713	Roller with pin.
22787	Pivot pin for pawl.
51728	Washer for pin ($\frac{3}{8}$ in. by $\frac{7}{8}$ in. by 0.0625 in.)
16118	Spring cotter for pin ($\frac{1}{8}$ in. by $\frac{3}{4}$ in.)
151714	Tension spring for pawl.
56809	Pin fastening spring to frame.
40334	OPERATING SHAFT, complete, with collars and gear.
40336	Stop collar for cam, with pin.
40335	Interlocking collar for operating shaft, with pin.
22790	Operating gear segment with pin (22 teeth, 10 pitch).
40337	AUXILIARY BREAK CAM for operating shaft.
40338	Compression spring for cam.
22792	Pinion for operating gear and controlling cylinder shaft (20 teeth, 10 pitch).
22794	Key for pinion ($\frac{1}{4}$ in. by $\frac{1}{4}$ in. by 1 in.)
22793	Retaining washer for pinion ($\frac{1}{4}$ in. by 1 in. by $\frac{1}{8}$ in. thick, brass, sp'l).
32817	Screw for No. 22793 (14-24, $\frac{1}{2}$ in. f. h. blued).
151715	Key for operating shaft and operating handle ($3\frac{3}{8}$ in. long).
22931	REVERSING CYLINDER, complete, with shaft, collar and star wheel.
151716	Moulded material body with contact segment.
151717	Shaft.
40439	Collar for shaft, with pin.
147785	STAR WHEEL with pin, must be fitted.
40339	Interlocking pawl with pin for spring, for reversing cylinder and operating shaft.
40341	Pivot pin for interlocking pawl.
21392	Washer for pin ($\frac{3}{8}$ in. by $\frac{3}{4}$ in. by 0.0625 in.)
16118	Spring cotter for pin ($\frac{1}{8}$ in. by $\frac{3}{4}$ in.)
151718	Tension spring for interlocking pawl.
40342	Spring holder.
40343	Screw fastening spring holder to frame ($\frac{3}{8}$ in.-16, $\frac{3}{4}$ in. fill. h.)
40440	PILOT VALVE BODY with sliding bar, bell crank lever and link.
151719	Screw fastening No. 40440 to frame (14-24, $\frac{7}{8}$ in. f. h. sherardized).
40441	Pilot valve stem.
40442	Leather washer for No. 40441 ($\frac{1}{8}$ in. by $\frac{1}{2}$ in. by $\frac{1}{16}$ in. thick).
40443	Pilot valve spring.
40444	Screw cap for pilot valve (threaded $\frac{5}{8}$ in.-24).
40445	Pilot valve nipple with coupling and nut.
40509	Interlocking lever with bar, for pilot valve.
40510	Pivot pin for No. 40509.
21392	Washer for pin ($\frac{3}{8}$ in. by $\frac{3}{4}$ in. by 0.0625 in.)
16118	Spring cotter for pin ($\frac{1}{8}$ in. by $\frac{3}{4}$ in.)
22951	AUXILIARY BREAK BLOWOUT BOX, complete, with pole piece, contact bases and magnet spool.
22952	Blowout box.
22953	Partition for box.
10305	Screw fastening partition to box (No. 6, $\frac{3}{4}$ in. f. h.)
150216	Cover with spring, for sight hole.
150217	Screw fastening No. 150216 to box (No. 8, $\frac{1}{2}$ in. r. h. sherardized).
22954	Pole piece for blowout box.
13848	Screw fastening pole piece to box (No. 10, $\frac{3}{4}$ in. f. h.)
121815	Screw fastening pole piece to frame (14-24, $\frac{1}{2}$ in. r. h. sherardized).
22955	Contact base, upper.
22956	Contact base, lower.
13848	Screw fastening No. 22955 to box (No. 10, $\frac{3}{4}$ in. f. h.)
13852	Screw fastening No. 22956 to box (No. 10, $\frac{7}{8}$ in. f. h.)
105331	Terminal screw for contact base (14-24, $\frac{3}{8}$ in. r. h. sherardized).

GENERAL ELECTRIC COMPANY

Parts of Type C-28, Forms C, D and E Controllers 54602-5

Cat. No.	Description
154193	Spring lock washer for No. 105331 ($\frac{17}{64}$ in. by $\frac{29}{64}$ in. by $\frac{3}{64}$ in. thick)
22957	AUXILIARY BREAK MAGNET SPOOL, wound complete, with leads and terminals
22778	Copper terminal for magnet spool lead
40344	SHAFT FOR AUXILIARY BREAK, complete, with lever arm and cam pawl
44605	Roller with pin, for cam pawl
151718	Tension spring for cam pawl
22942	Spring post fastening spring to cap for top of controller (threaded $\frac{3}{8}$ in.-16)
22943	CONTACT BLOCK, complete, with contact fingers, for auxiliary break
22944	Contact block
22945	Screw fastening contact block to lever arm (14-24, $1\frac{1}{8}$ in. f. h.)
22946	Washer plate for No. 22945
22947	UNREINFORCED CONTACT FINGER with spring
22949	Finger stop
1193	Screw fastening Nos. 22947, 22949 to contact block (8-32, $\frac{1}{2}$ in. f. h.)
22950	Washer plate for No. 1193
147787	CONTROLLING CONTACT BLOCK, complete, with contact bases and fingers
147788	Contact block with contact bases, without fingers
144977	Screw fastening block to frame (14-24, $1\frac{1}{4}$ in. r. h. sherardized)
14426	Washer for No. 144977 ($\frac{17}{64}$ in. by $\frac{1}{2}$ in. by 0.060 in. brass)
22960	UNREINFORCED OPERATING CONTACT FINGER with spring
38065	Complete set of operating contact fingers (includes 11 No. 22960 and 2 No. 22947)
22778	Copper terminal for contact finger
105331	Screw fastening Nos. 22960, 22778 to contact base (14-24, $\frac{3}{8}$ in. r. h. sherardized)
154193	Spring lock washer for No. 105331 ($\frac{17}{64}$ in. by $\frac{29}{64}$ in. by $\frac{3}{64}$ in. thick)
22962	Copper connection strip for contact bases
22963	Finger shield for controlling contact block
150239	Screw fastening finger shield to block (No. 10, $\frac{5}{8}$ in. r. h. sherardized)
22964	Trolley shield for controlling contact block
151720	Screw fastening trolley shield to block (No. 10, $\frac{5}{8}$ in. f. h. sherardized)
22965	Insulation strip between controlling contact block and frame
22966	REVERSING CONTACT BLOCK, complete, with contact bases and fingers
22967	Reversing contact block with contact bases, without fingers
144977	Screw fastening block to frame (14-24, $1\frac{1}{4}$ in. r. h. sherardized)
14426	Washer for No. 144977 ($\frac{17}{64}$ in. by $\frac{1}{2}$ in. by 0.060 in. brass)
22968	REVERSING CONTACT FINGER
38066	Complete set of reversing contact fingers (includes 4 No. 22968)
22778	Copper terminal for contact finger
22969	Copper connection strip for contact fingers
105331	Screw fastening Nos. 22968, 22778, 22969 to contact base (14-24, $\frac{3}{8}$ in. r. h. sherardized)
154193	Spring lock washer for No. 105331 ($\frac{17}{64}$ in. by $\frac{29}{64}$ in. by $\frac{3}{64}$ in. thick)
151721	Insulation plate between reversing contact block and frame
22970	Insulation shield for side of reversing contact block
10214	Screw fastening No. 22970 to block (No. 8, $\frac{1}{2}$ in. f. h.)
22971	Fiber cleat for holding auxiliary break and reversing contact block wires to frame
40511	Fiber cleat for holding reversing contact block wire to frame
133475	Screw fastening No. 22971 to frame (14-24, $1\frac{1}{8}$ in. r. h. sherardized)
150751	Screw fastening No. 40511 to frame (10-32, 1 in. r. h. sherardized)
148636	Spring lock washer for No. 150751 ($\frac{13}{64}$ in. by $\frac{25}{64}$ in. by 0.031 in.)
40512	Terminal block, complete
128612	Terminal screw for No. 40512 (14-24, 1 in. r. h. sherardized)
22213	Nut for No. 128612 (14-24, hex. flat brass)
154193	Spring lock washer for No. 128612 ($\frac{17}{64}$ in. by $\frac{29}{64}$ in. by $\frac{3}{64}$ in. thick)
22778	Copper terminal for No. 128612
127116	Screw fastening No. 40512 to frame (14-24, $\frac{5}{8}$ in. r. h. sherardized)
44606	Wire guard

GENERAL ELECTRIC COMPANY

54602-6 Parts of Type C-28, Forms C, D and E Controllers

C-28-D CONTROLLER

Cat. No.	Description
34343	Operating handle
29184	*Reversing handle
<i>Following are the parts of the C-28-D controller which differ from those of the C-28-C:</i>	
147789	AUXILIARY BREAK BLOWOUT BOX, complete, with pole piece, contact bases and magnet spool.....
40513	AUXILIARY BREAK MAGNET SPOOL, wound complete, with leads and terminals.....
147790	CONTROLLING CONTACT BLOCK, complete, with contact bases and fingers.....
44607	Contact block with contact bases, without fingers.....
22972	Fiber cleat for holding auxiliary break and reversing contact block wires to frame.....
40514	Terminal block, complete.....

C-28-E CONTROLLER

34343	Operating handle
29184	*Reversing handle
<i>Following are the parts of the C-28-E controller which differ from those of the C-28-C:</i>	
40333	FRAME, complete, fitted with bearing and cap screws, for controlling cylinder shaft. Includes pole piece stop, magnet core, binding nut for magnet spool, soft rubber packing and all spring and pivot pins riveted in position.....
22981	Sheet iron cover, complete.....

* Not included in complete controller. Must be ordered separately.

GENERAL ELECTRIC COMPANY

Parts of Type C-28, Forms C, D and F Controllers 54602-7

INDEX TO CATALOGUE NUMBERS

CAT. NO. PAGE	CAT. NO. PAGE	CAT. NO. PAGE	CAT. NO. PAGE	CAT. NO. PAGE	CAT. NO. PAGE
1188-2	22776-2	22956-4	40337-4	40514-6	150153-1
1193-5	22777-2	22957-5	40338-4	44605-5	150154-1
10214-5	22778-2, 5	22960-5	40339-4	44606-5	150216-4
10305-4	22782-2	22962-5	40341-4	44607-6	150217-4
13635-2	22783-2	22963-5	40342-4	51728-4	150239-5
13848-4	22784-2	22964-5	40343-4	56809-4	150715-1
13852-4	22786-4	22965-5	40344-5	105331-4, 5	150751-5
14410-1	22787-4	22966-5	40432-1	121815-4	151705-1
14426-5	22790-4	22967-5	40433-1	127116-5	151706-1
14645-1	22792-4	22968-5	40434-1	128612-5	151707-1
14646-1	22793-4	22969-5	40435-1	133475-5	151708-1
16118-4	22794-4	22970-5	40436-2	133716-1	151709-1
19628-2	22931-4	22971-5	40437-2	144977-5	151710-1
21392-1	22942-5	22972-6	40439-4	147785-4	151711-1
22213-5	22943-5	22980-1	40440-4	147787-5	151712-2
22761-1	22944-5	22981-6	40441-4	147788-5	151713-4
22762-1	22945-5	29184-1, 6	40442-4	147789-6	151714-1
22763-1	22946-5	32817-4	40443-4	147790-6	151715-4
22764-1	22947-5	34343-1, 6	40444-4	148636-5	151716-4
22767-1	22949-5	38065-5	40445-1	150143-1	151717-4
22769-1	22950-5	38066-5	40509-4	150145-1	151718-4, 5
22770-1	22951-4	40333-6	40510-4	150146-1	151719-4
22771-1	22952-4	40334-4	40511-5	150147-1	151720-5
22772-1	22953-4	40335-4	40512-5	150148-1	151721-5
22773-2	22954-1	40336-4	40513-6	150150-1	154193-2, 5
22775-2	22955-4				

GENERAL ELECTRIC COMPANY

PRINCIPAL OFFICES, SCHENECTADY, N. Y.

SALES OFFICES (Address nearest office)

Atlanta, Ga.	Third National Bank Building
Baltimore, Md.	Electrical Building
Birmingham, Ala.	Brown-Marx Building
Boise, Idaho	Idaho Building
Boston, Mass.	81 State Street
Buffalo, N. Y.	Electric Building
Butte, Mont.	Electric Building
Charleston, W. Va.	Charleston National Bank Building
Charlotte, N. C.	Commercial National Bank Building
Chattanooga, Tenn.	James Building
Chicago, Ill.	Monadnock Building
Cincinnati, Ohio	Provident Bank Building
Cleveland, Ohio	The Illuminating Building
Columbus, Ohio	Columbus Savings & Trust Building
Dayton, Ohio	Schwind Building
Denver, Colo.	First National Bank Building
Des Moines, Iowa	The Hippee-Polk Building
Detroit, Mich.	Dime Savings Bank Bldg. (Office of Soliciting Agent)
Elmira, N. Y.	Hulet Building
Erie, Pa.	Marine National Bank Building
Fort Wayne, Ind.	Fort Wayne Electric Works
Hartford, Conn.	Hartford National Bank Building
Indianapolis, Ind.	Traction Terminal Building
Jacksonville, Fla.	Heard National Bank Building
Joplin, Mo.	Miners' Bank Building
Kansas City, Mo.	Dwight Building
Knoxville, Tenn.	Bank & Trust Building
Los Angeles, Cal.	124 West Fourth Street
Louisville, Ky.	Starks Building
Memphis, Tenn.	Randolph Building
Milwaukee, Wis.	Public Service Building
Minneapolis, Minn.	410 Third Ave., North
Nashville, Tenn.	Stahlman Building
New Haven, Conn.	Second National Bank Building
New Orleans, La.	Maison-Blanche Building
New York, N. Y.	30 Church Street
Niagara Falls, N. Y.	Gluck Building
Omaha, Neb.	Union Pacific Building
Philadelphia, Pa.	Witherspoon Building
Pittsburg, Pa.	Oliver Building
Portland, Ore.	Electric Building
Providence, R. I.	Turks Head Building
Richmond, Va.	Virginia Railway & Power Building
Rochester, N. Y.	Granite Building
St. Louis, Mo.	Perice Building
Salt Lake City, Utah	Newhouse Building
San Francisco, Cal.	Rialto Building
Seattle, Wash.	Colman Building
Spokane, Wash.	Paulsen Building
Springfield, Mass.	Massachusetts Mutual Building
Syracuse, N. Y.	Onondaga County Savings Bank Building
Toledo, Ohio	Spitzer Building
Washington, D. C.	Evans Building
Youngstown, Ohio	Wick Building

For TEXAS, OKLAHOMA and ARIZONA Business refer to
 Southwest General Electric Co. (Formerly Hobson Electric Co.)
 Dallas, Tex. 1701 N. Market Street
 El Paso, Tex. 500-2 San Francisco Street
 Houston, Tex. Third and Allen Streets
 Oklahoma City, Okla. Insurance Building

Motor Agencies in all large cities and towns.

FOREIGN SALES { Schenectady, N. Y., Foreign Dept.
 OFFICES { New York, N. Y., 30 Church Street
 London, E. C., England, 83 Cannon Street

For all CANADIAN Business refer to
 Canadian General Electric Co., Ltd., Toronto, Ont.